

Cation- π Interactions in Sodiated Phenylalanine Complexes: Is Phenylalanine in the Charge-Solvated or Zwitterionic Form?

Fung Ming Siu,[†] Ngai Ling Ma,^{*,‡} and Chun Wai Tsang^{*,†}

Department of Applied Biology and Chemical Technology
Hong Kong Polytechnic University
Hung Hom, Hong Kong, P. R. China
Chemical Application Division
Institute of High Performance Computing
89C Science Park Drive, #02-11/12
The Rutherford, Singapore 118261

Received October 11, 2000

Revised Manuscript Received March 5, 2001

Recent studies have shown that cation- π interactions, the electrostatic binding between a cation and the π ring of phenylalanine (Phe), tyrosine (Tyr), and tryptophan (Trp), are common motifs in protein structures.¹ This type of noncovalent interaction has been hypothesized to play important roles in molecular recognition.² In particular, Na⁺/K⁺ cation- π interactions are implicated in the biological function of specific enzymes and the selectivity of Na⁺/K⁺ ion channels.³

Biologically, it is well-known that amino acids exist in the "free-acid" and "dipolar" forms.⁴ Cations can stabilize the negatively charged carboxylate end of the dipolar amino acid to form stable metalated zwitterionic structures (ZW), as opposed to the charge-solvation (CS) forms. The *intrinsic* and relative stability of the CS and ZW forms, in the absence of solvent, has been the subject of many theoretical⁵ and experimental⁶ investigations. Williams and co-workers first demonstrated that mainly due to the high basicity of the guanidine side chain, arginine is in the ZW form when protonated in the gas phase.^{7a} Later, it was shown that alkali metal (Na, K, Rb, and Cs)-cationized arginine is also in the ZW form.^{7b} Recently, amino acids with proton affinities larger than 217 kcal mol⁻¹, including Phe (PA = 220.6 kcal mol⁻¹), is predicted to be in the ZW form when sodiated.⁸

The effect of cation- π interactions on the relative stability of CS versus ZW forms of metal-cationized amino acids has not been considered previously. Recent findings indicate that the phenyl- π face is, in fact, one of the binding sites involved in the Na⁺/K⁺ bound complexes of Phe, Tyr, and Trp.⁹ With these

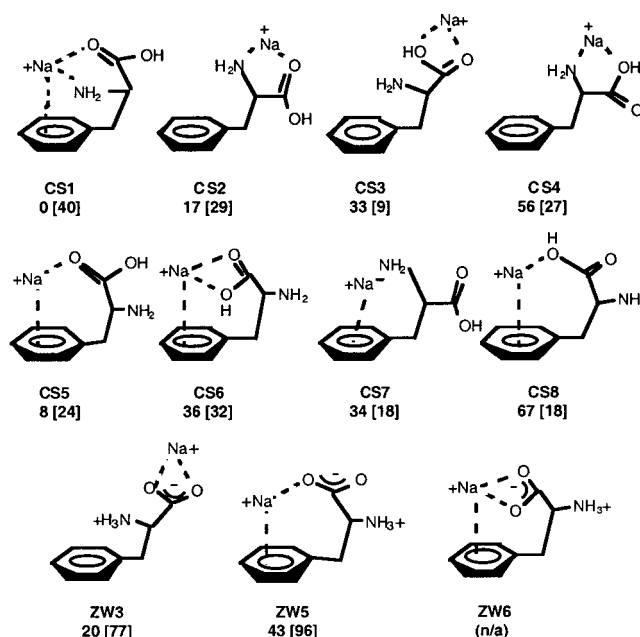

Figure 1. Schematic representation of [Na⁺-Phe] complexes. Charge-solvation and zwitterionic structures are abbreviated as CS and ZW, respectively. The first value, and the value in square brackets, correspond to relative energies (in kJ mol⁻¹, with reference to CS1 with absolute affinity of 201.2 kJ mol⁻¹) and deformation energies (in kJ mol⁻¹), respectively.

considerations in mind, we adopt Na⁺ and Phe as a prototype to elucidate the possible roles of cation- π interaction in determining the relative stability of CS and ZW forms of metal-cationized aromatic amino acids in the gas phase.

We carried out systematic theoretical studies of the Na⁺-Phe complex¹⁰ and found that Na⁺ may interact with Phe via eight CS and two ZW modes¹¹ of binding (Figure 1). The most stable mode of binding, in agreement with that determined by Dunbar,⁹ is a tridentate mode (denoted as CS1) where the Na⁺ interacts simultaneously with phenyl (π), amide carbonyl (C=O), and the amino group (NH₂) at the N-terminus. Despite highly strained (largest deformation energy, E_{def} , among all CS species),¹² the tridentate CS1 mode of binding is still the most stable, indicating that the interaction between the cation and the π ring is, in general, highly stabilizing.

(9) (a) Ryzhov, V.; Dunbar, R. C.; Cerda, B.; Wesdemiotis, C. *J. Am. Soc. Mass Spectrom.* **2000**, *11*, 1037–1046. (b) Dunbar, R. C. *J. Phys. Chem. A* **2000**, *104*, 8067–8074. In ref 9 (b), five CS binding modes were considered between the alkali metal cations and the phenylalanine. However, the stability of ZW forms of these species was not considered.

(10) Sodium cation affinities are calculated at the B3-LYP/6-311+G-(3df,2p)/B3-LYP/6-31G(d) level and corrected with scaled (0.8929) HF/6-31G(d) zero-point energies. The calculated Na⁺ affinity for benzene using this approach (100.2 kJ mol⁻¹) is in excellent agreement with sophisticated ab initio calculations [Feller, D. *Chem. Phys. Lett.* **2000**, *322*, 543–548], and experimental values reported [Amicangelo, J. C.; Armentrout, P. B. *J. Phys. Chem. A* **2000**, *104*, 11420–11432; McMahon, T. B.; Ohanessian, G. *Chem. Eur. J.* **2000**, *6*, 2931–2941; Guo, B. C.; Purnell, J. W.; Castleman, A. W., Jr. *Chem. Phys. Lett.* **1990**, *168*, 155–160]. Furthermore, the relative stability of the key species reported here is insensitive to the choice of geometry and level of zero-point energy corrections, and is in good agreement with that estimated with MP2 methods. Data on the validation of the B3-LYP/6-311+G-(3df,2p)/B3-LYP/6-31G(d) protocol are contained in the accompanying Supporting Information.

(11) Out of the eight CS modes of binding, as long as the amino group at N-terminus is not involved in Na⁺ binding, the complex can in principle isomerize into the corresponding ZW form. Hence, only CS3, CS5, CS6, and CS8 can form ZW species. While CS5 and CS8 are two distinct structures in the CS form, they are identical when isomerize to the ZW form. Moreover, we have not been able to obtain a stable ZW6 species, as optimizing from plausible structures for ZW6 invariably leads to ZW3.

[†] Hong Kong Polytechnic University.

[‡] Institute of High Performance Computing.

(1) (a) Minoux, H.; Chipot, C. *J. Am. Chem. Soc.* **1999**, *121*, 10366–10372. (b) Gallivan, J. P.; Dougherty, D. A. *Proc. Natl. Acad. Sci. U.S.A.* **1999**, *96*, 9459–9464.

(2) Ma, J. C.; Dougherty, D. A. *Chem. Rev.* **1997**, *97*, 1303–1324.

(3) (a) Nayal, M.; Di Cera, E. *J. Mol. Biol.* **1996**, *256*, 228–234. (b) Wouters, J. *Protein Sci.* **1998**, *7*, 2472–2475. (c) DeWall, S. L.; Meadows, E. S.; Barbour, L. J.; Gokel, G. W. *Proc. Natl. Acad. Sci. U.S.A.* **2000**, *97*, 6271–6276. (d) Wright, S. N.; Wang, S. Y.; Wang, G. K., *Mol. Pharmacol.* **1998**, *54*, 733–739. (e) Silverman, S. K.; Lester, H. A.; Dougherty, D. A. *Biophys. J.* **1998**, *75*, 1330–1339. (f) Nakamura, R. L.; Anderson, J. A.; Gaber, R. F. *J. Biol. Chem.* **1997**, *272*, 1011–1018.

(4) Zubay, G. L. *Biochemistry*; Macmillan: New York; Collier Macmillan: London, 1988.

(5) (a) Jensen, J. H.; Gordon, M. S. *J. Am. Chem. Soc.* **1995**, *117*, 8159–8170. (b) Ding, Y. B.; Krogh-Jespersen, K. *J. Comput. Chem.* **1996**, *17*, 338–349. (c) Hoyau, S.; Ohanessian, G. *Chem. Eur. J.* **1998**, *4*, 1561–1569.

(6) (a) Price, W. D.; Jockusch, R. A.; Williams, E. R. *J. Am. Chem. Soc.* **1998**, *120*, 3474–3484. (b) Chapo, C. J.; Paul, J. B.; Provencal, R. A.; Roth, K.; Saykally, R. J. *J. Am. Chem. Soc.* **1998**, *120*, 12956–12957. (c) Wytenbach, T.; Witt, M.; Bowers, M. T. *Int. J. Mass Spectrom.* **1999**, *182*/183, 243–252. (d) Cerda, B. A.; Wesdemiotis, C. *Analyst* **2000**, *125*, 657–660.

(7) (a) Price, W. D.; Jockusch, R. A.; Williams, E. R. *J. Am. Chem. Soc.* **1997**, *119*, 11988–11989. (b) Jockusch, R. A.; Price, W. D.; Williams, E. R. *J. Phys. Chem. A* **1999**, *103*, 9266–9274.

(8) Wytenbach, T.; Witt, M.; Bowers, M. T. *J. Am. Chem. Soc.* **2000**, *122*, 3458–3464.

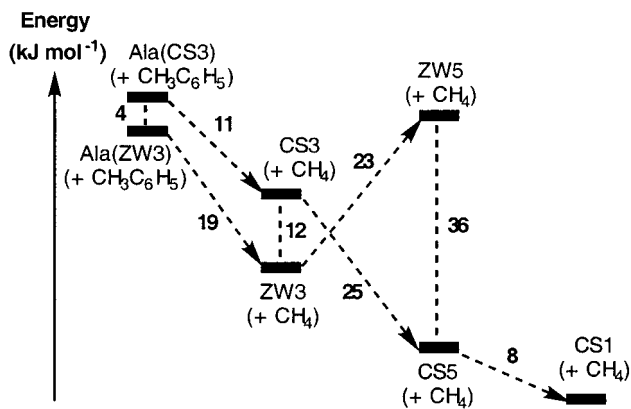
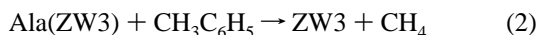
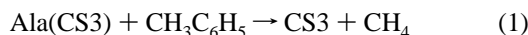

Figure 2. Energy level diagram for sodiated alanine and phenylalanine. The species in brackets are added to conserve the type and number of atoms so that all systems can be compared on the same potential surface.

The two metal-cationized zwitterionic complexes, ZW3 and ZW5, are much less stable than CS1. To elucidate the effect of the phenyl group acting solely as a side chain (not involved in cation- π binding) in ZW3 on the relative stability of the CS versus ZW modes, two methyl stabilization reactions¹³ have been constructed:



In the above equations, Ala(CS3) and Ala(ZW3) are the charge-solvation and zwitterionic forms of Na⁺-alanine complexes, in the same mode of binding as CS3 and ZW3 (i.e., the Na⁺ binds to the carboxylic/carboxylate oxygens), respectively. Both reactions 1 and 2 are exothermic (Figure 2), suggesting that the phenyl group in phenylalanine stabilizes both the CS3 and ZW3 forms when compared to toluene (methylbenzene). The higher exothermicity of reaction 2 indicates that the stabilization effect of the phenyl group is more significant for ZW3 than CS3. The result can be rationalized as follows. In the case of CS3, the phenyl ring helps to stabilize the Na⁺, possibly due to increased polarizability of the side chain. On the other hand, for ZW3, apart from stabilizing the Na⁺, the more polarizable phenyl π ring also helps to disperse the charge on NH₃⁺ at the N-terminus. Given the difference in chemical softness between -H and -phenyl,¹⁴ it is not surprising that the softer phenyl side chain is playing a more significant role in stabilizing the charges in the ZW3 complex.

The relative stability for the CS5/ZW5 pair is opposite to that of the CS3/ZW3 pair. In the presence of cation- π interaction, the stability of the charge-solvation CS5 conformation is enhanced, while the zwitterionic ZW5 conformation is de-stabilized (Figure 2). The instability of the ZW5 conformation is probably

(12) Deformation energies (E_{def} , kJ mol⁻¹), defined as $E(\text{neutral Phe in the complexed conformation}) - E(\text{neutral Phe in the most stable, uncomplexed form})$, is calculated at the B3-LYP/6-31G(d) level of theory. It represents the destabilization energy arising from structural strain, electrostatic repulsion, and disruption of hydrogen bonds that the phenylalanine has to bear in order to complex with the metal cation.

(13) Hehre, W. J.; Radom, L.; Schleyer, P. v. R.; Pople, J. A. *Ab Initio Molecular Orbital Theory*; Wiley: New York, 1986.

(14) Baeten, A.; De Proft, F.; Geerlings, P. *Int. J. Quant. Chem.* **1996**, *60*, 931-939.

due to strong electrostatic repulsion among the binding sites. Our rationalization is based largely on deformation energy considerations: ZW5 has a substantially larger deformation energy (96 kJ mol⁻¹) relative to that of CS5 (24 kJ mol⁻¹). As the CS5/ZW5 pair is structurally very similar, the difference in E_{def} is due to the variation in the magnitude of the electrostatic attractive/repulsive forces in these two systems. One expects larger electrostatic repulsion between *one* of the negatively charged carboxylate oxygens and the electron-rich phenyl π ring in ZW5, than between the neutral carboxylic acid group and phenyl π ring in CS5. On this note, we can also understand why a ZW6-like complex may not exist. To form a ZW6-like complex, *both* negatively charged oxygens in the carboxylate group would be located closely to the electron-rich phenyl group. Hence, the E_{def} of a ZW6-like species would be expected to be even larger than ZW5. This large deformation energy derived from electrostatic repulsion is likely to dominate in ZW6-like complexes, leading to greater instability of this zwitterionic conformation.

The roles of the phenyl group now become clear. When the phenyl π ring is not involved in binding to the cation, it acts as a "sink" to stabilize the positive charge of both the Na⁺ and the NH₃⁺ at the N-terminus so that the ZW3 conformation is more stable than CS3. When the phenyl group is involved in binding with a metal cation like Na⁺, electrostatic repulsion between the phenyl group and the negatively charged carboxylate group would, in fact, destabilize the ZW complexes. Our preliminary results show that the difference in the ionic sizes (Li⁺/Na⁺/K⁺) does have some effects on the relative stability of the CS and ZW conformations. A full analysis of alkali metal cation size effect on the stability of CS/ZW forms will be reported in due course.

In conclusion, our results suggest that the relative stability of the CS/ZW forms of metal-cationized amino acids could be greatly affected if the side chain of the amino acid is involved in the cation binding. For sodiated phenylalanine, the presence of cation- π interactions confers greater stability to the charge-solvation conformations (CS1 and CS5) than the zwitterion ZW3, and destabilizes ZW5- and ZW6-like conformations. Our preliminary results also indicate that the conclusions derived from Na⁺-Phe complexes can be extended to the other aromatic amino acids (e.g., Tyr and Trp).

Acknowledgment. We thank Professor R. C. Dunbar for his preprints (ref 9), and helpful discussions. N.L.M. thanks the Institute of High Performance Computing and National University of Singapore for generous allocation of supercomputer time. The award of a Hong Kong Polytechnic University research studentship (acc. no. GV-540) to F.M.S. and an Area of Strategic Development Fund (acc. no. A024) to C.W.T. are gratefully acknowledged.

Supporting Information Available: Tables of B3-LYP/6-31G(d) optimized geometries (Cartesian coordinates) for (a) the most stable form of phenylalanine, (b) sodiated phenylalanine (CS1-CS8, ZW3 and ZW5), and (c) sodiated alanine (Ala(CS3) and Ala(ZW3)) along with electronic energies calculated at the B3-LYP/6-311+G(3df,2p) level, corrected with scaled (0.8929) at HF/6-31G(d) zero-point energy; affinities obtained at the B3-LYP/6-311+G(3df,2p)/B3-LYP/6-31+G(d) and MP2/6-311+G(3df,2p)/B3-LYP/6-31G(d) levels for CS1, CS3, CS5, ZW3, and ZW5; relative affinities corrected with scaled (0.9806) B3-LYP/6-31G(d) frequencies; relative affinities and Gibbs free energies at 298 K; and procedure for setting up initial sodiated phenylalanine structures for geometry optimization (PDF). This material is available free of charge via the Internet at <http://pubs.acs.org>.

JA0056872